

# Engineering Drawing (E 122) Engineering Graphics (E 125)

LECTURE NOTES

## 1 INTRODUCTION

## 2 DRAFTING BASICS --- GEOMETRY & SHAPE DESCRIPTION

## 3 ORTHOGRAPHIC VIEWS & CAD I

### I. Preliminaries

A. (CT brings – Foam part, camera)

B. Last time

1. Sketching, lettering, sheet formats, scale, line types
2. Geometry, projection, surfaces, line rules

### II. Theory of projection for 1 view

A. Recall –

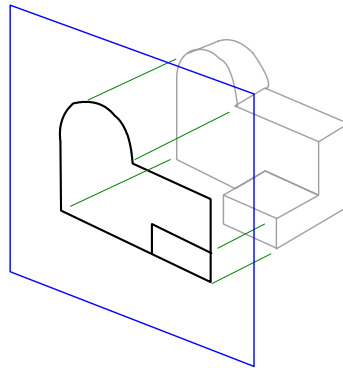

### III. Third angle projection

A. Glass box concept

1. Imagine the part suspended and \_\_\_\_\_ inside a \_\_\_\_\_.
2. Project \_\_\_\_\_ lines of sight onto the \_\_\_\_\_ to create different \_\_\_\_\_ of the part on each side.
3. \_\_\_\_\_ the box to get the \_\_\_\_\_ as seen from \_\_\_\_\_.

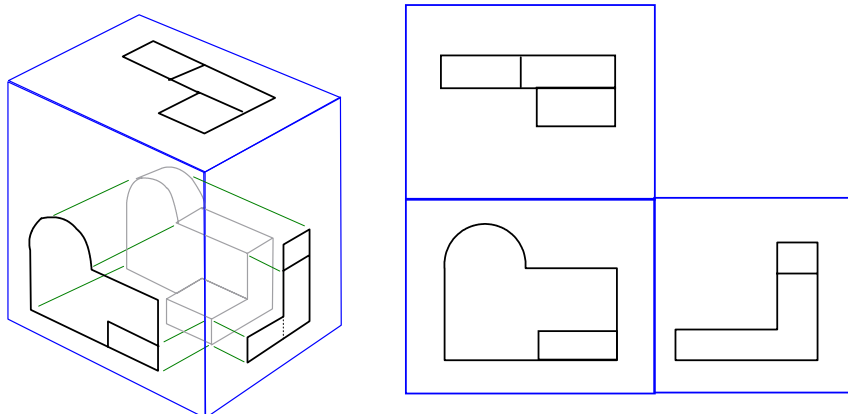

B. Result

1. Top view is placed \_\_\_\_\_ the front view.
2. Right side view is placed to the \_\_\_\_\_ of the front view.

C. \_\_\_\_\_ (American National Standards Institute) – used in \_\_\_\_\_.

D. Ways to think of it:

1. Rolling the part \_\_\_\_\_ table to see the different sides
2. Swinging the “\_\_\_\_\_” (or back side).

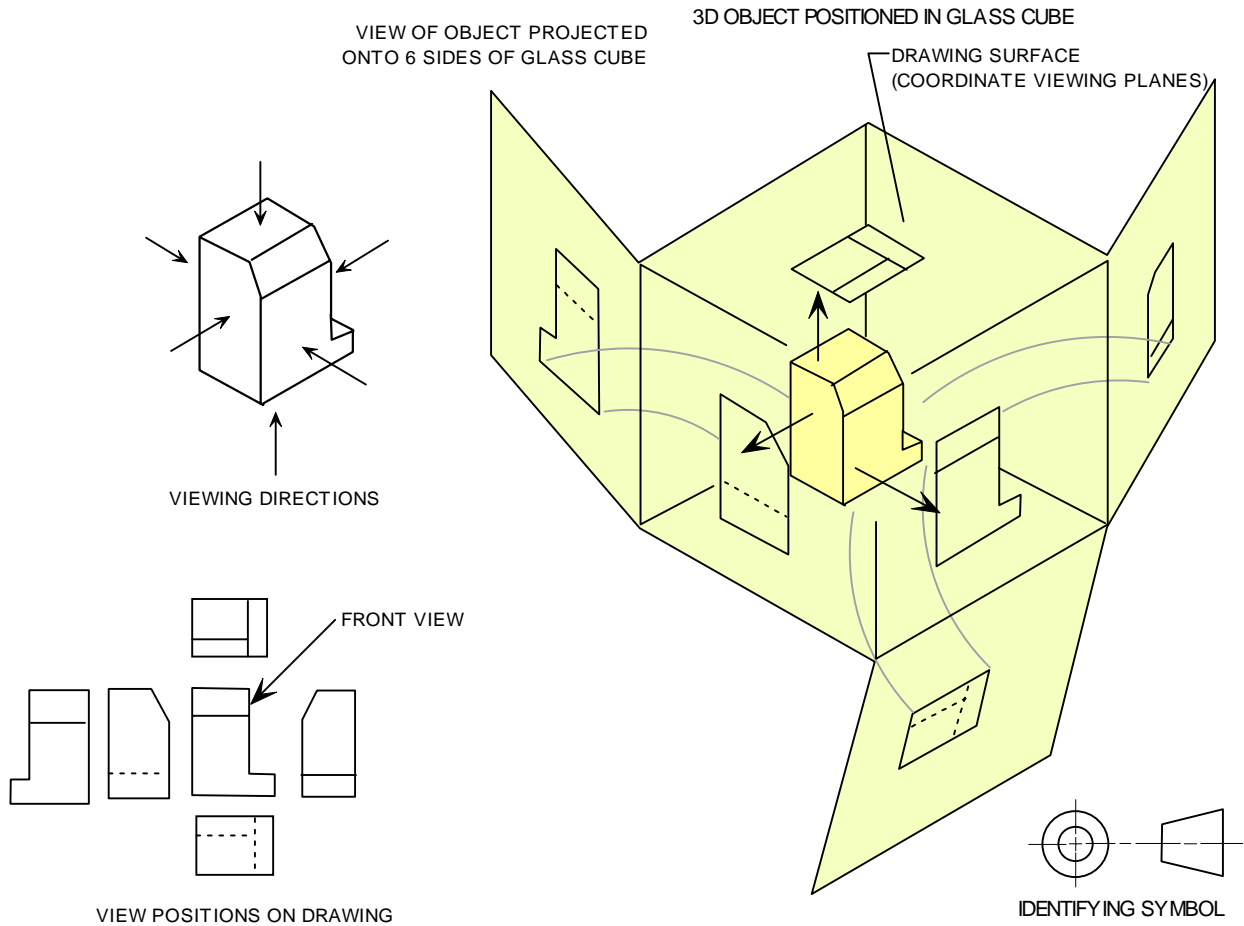

IV. First angle projection

- A. Use glass box concept, but project in \_\_\_\_\_ direction – \_\_\_\_\_ the part to the \_\_\_\_\_ side.
- B. Unfold box – look at resulting views on \_\_\_\_\_ of box sides.
- C. Result
  1. Top view is \_\_\_\_\_ the front view.
  2. Right view is \_\_\_\_\_ of the front view.

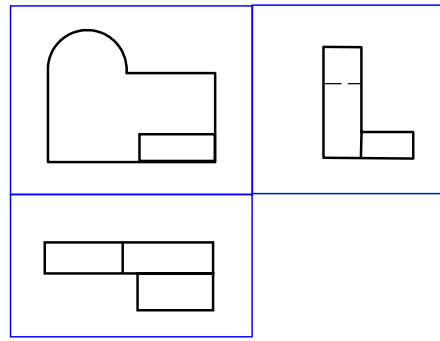
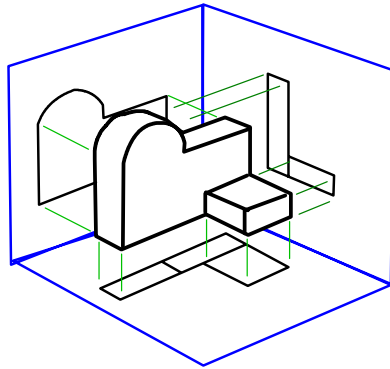

D. \_\_\_\_\_ (Europe & Asia)

E. Ways to think of it:

1. Roll the part \_\_\_\_\_ glass table to see the different sides.
2. Swinging the \_\_\_\_\_ (or front).

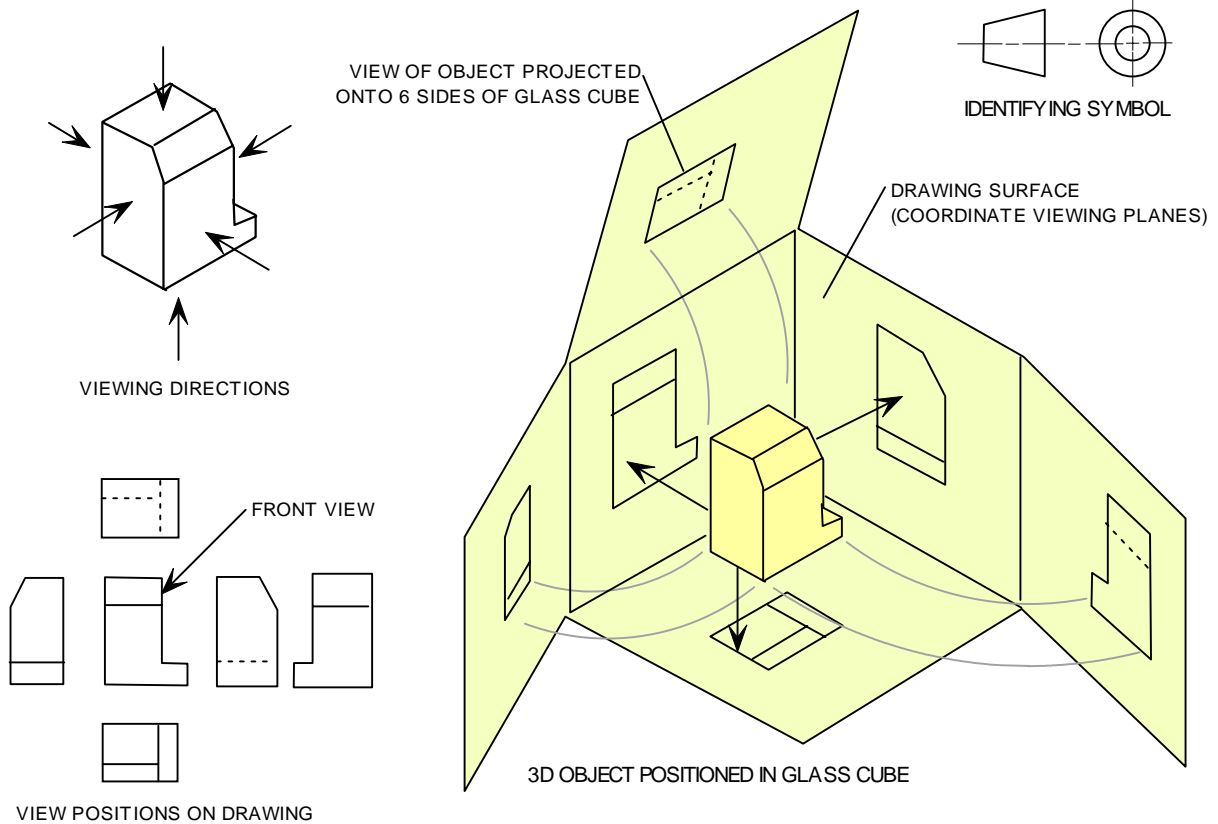

### V. Comparing first and third angle projection

A. Individual views are exactly the SAME between 1st and 3rd angle. Only the \_\_\_\_\_ of the views relative to each other are different.

### VI. Lesson

- A. There is a correct \_\_\_\_\_ and \_\_\_\_\_ for views (you don't just put the views wherever you feel like it).
- B. We will use \_\_\_\_\_ projection.

## VII. Orthographic Concepts

### A. Principal Planes in F, R, & T views

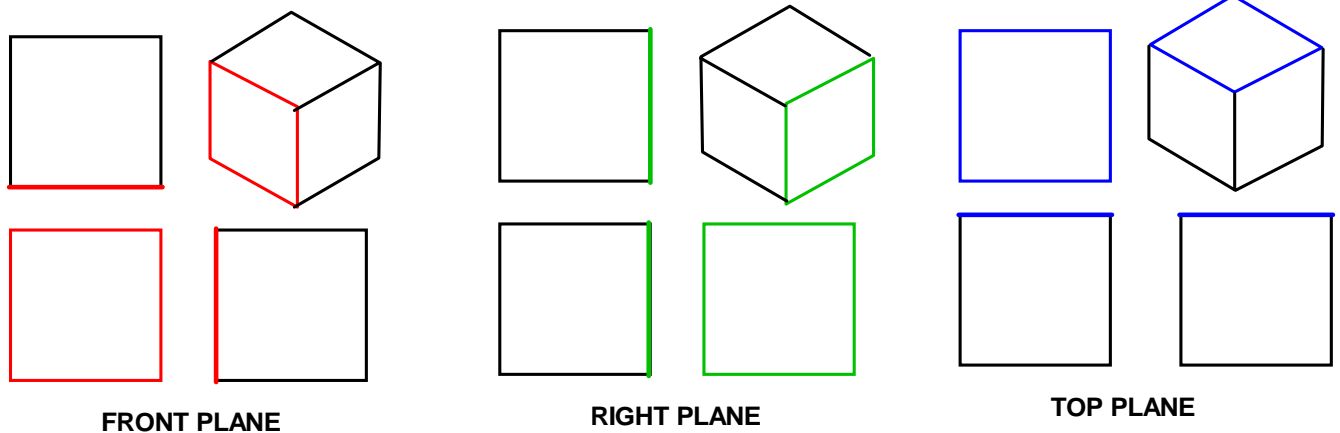

### B. Inclined Planes in F, R, & T views

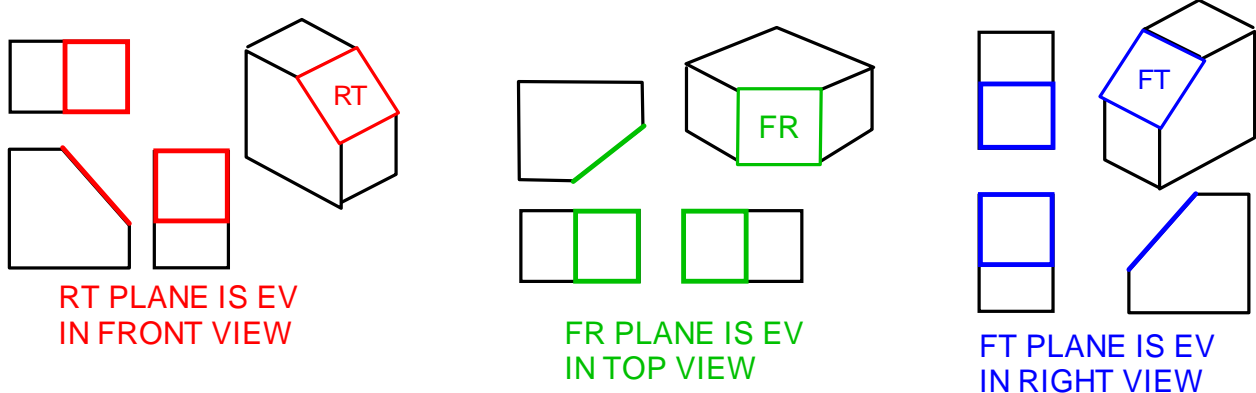

### C. Oblique Planes in F, R, & T views

## VIII. Orthographic practice (simple parts)

### A. First step – mark each flat surface as follows

1. F – surfaces that “face” the front plane
2. T – surfaces that “face” the top plane
3. R – surfaces that “face” the right plane
4. TR – surfaces that can be seen in the top & right views (but don’t face any plane directly).
5. FR – surfaces that can be seen in the front & right views (& don’t face any plan
6. TRF – surfaces can be seen in top, right, and front views.

### B. Note

1. Surfaces with 1 letter are \_\_\_\_\_.
2. Surfaces with 2 letters are \_\_\_\_\_.
3. Surfaces with 3 letters are \_\_\_\_\_.

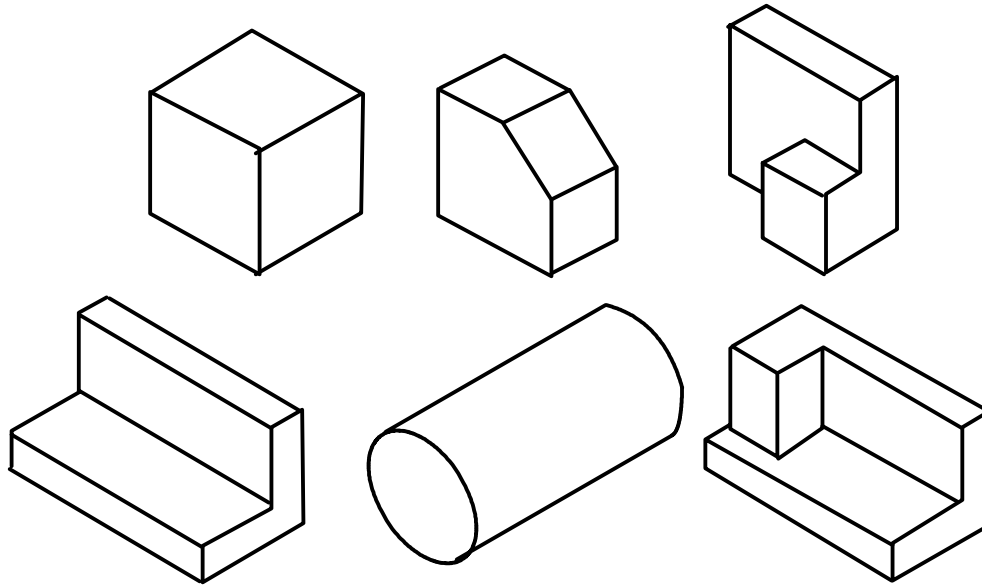

C. Practice with slightly tougher parts

FIND MEDIUM PARTS HERE!

IX. AutoCAD Intro (see handout) (week 3)

A. Topics: intro, mouse, keyboard, opening, classic setup, using my template, coordinates, line, select, erase, undo, keyboard shortcuts, zoom, pan, plot, save, exiting